



ENQUIRY REF. No.	KAPL/CG/011/1662
DATE	29/10/2024
DUE DATE	11/11/2024 till 1:00 PM

Dear Sir,

Please submit your lowest and competitive offer in a SEALED ENVELOPE, DULY SUPERSCRIBING OUR ABOVE ENQUIRY REF. NO., DATE and DUE DATE on it. Mentioned other details of F.O.R terms, Taxes, Credit period, Delivery offered, Name of the Make, Detailed Specification etc., for the below Supply or Service

SI No	ItemCode	Item Description	Uom	Qty
01	TDP2029	DYNAMIC PASS BOX,MOC:SS 304	NOS	02

Please ensure that your offer reaches us on or **'before Due Date by courier OR Speed post or by Hand in sealed cover only to below office address:**

**M/s. Karnataka Antibiotics and Pharmaceuticals Limited**  
**Plot No.37, Arka The Business Centre,NTTF Main Road, Peenya Industrial Area**  
**2<sup>nd</sup> Phase, Bengaluru-560058 Ph. No.080-23571590**

**TECHNICAL CLARIFICATION**

**1.SPECTIONS ATTACHED**

**OTHER TERMS:**

- |                                 |                  |
|---------------------------------|------------------|
| 1. F.O.R TERMS                  | : DOOR DELIVERY  |
| 2. GST %                        | : PLEASE SPECIFY |
| 3. PACKING & FORWARDING CHARGES | : NOT APPLICABLE |
| 4. CREDIT PERIOD                | : 30 DAYS        |
| 5. DELIVERY OFFERED             | : PLEASE SPECIFY |

**NOTE:**

01. IF YOU ARE NOT PARTICIPATING IN THE TENDER PLEASE SEND A REGRET LETTER.

02. VENDOR HAS TO QUOTE AS PER OUR TENDER IN YOUR COMPANY LETTER HEAD.

**03. QUOTATION MUST BE SUBMITTED IN TWO SEALED COVERS (TECHNICAL & COMMERCIAL/PRICE BID) SEPARATELY AND IN ONE ENVELOPE OR ELSE YOUR PROPOSAL WILL NOT BE CONSIDERED.**

**IF YOU NEED ANY CLARIFICATION, PLEASE CONTACT US.**

Thanking you,

Yours faithfully,  
For KARNATAKA ANTIBIOTICS  
& PHARMACEUTICALS LIMITED

  
YUVARAJA. M  
DY. MANAGER – PURCHASE DEPT.  
MOB: 9945317873

# ENGINEERING AND PROJECT DEPARTMENT

## MATERIAL REQUISITION

Date : 17/09/2024

stores

Through : HOD - E&P

Machine Name and Details : Pass Box

*(Signature)*  
27/9/24  
DGM (E&P)

Section : DPR-1

Sl. No. : 333

Following are the details :

Sl. No.	Item Code No.	Item Description	UOM	Qty.	Required Date	P.R. No. & Date	Remarks
01	TDP 2029	Dynamic Pass Box 750X600X750 (890X680X1600) moc: se <u>specifications</u> as per attached drawing	Nos	02			Required for DPR-1 Section Seal Sanitation room and De pack room (Use bi-kitten per audit CARA Compliance purpose)
<i>Suggested Vendor</i>							

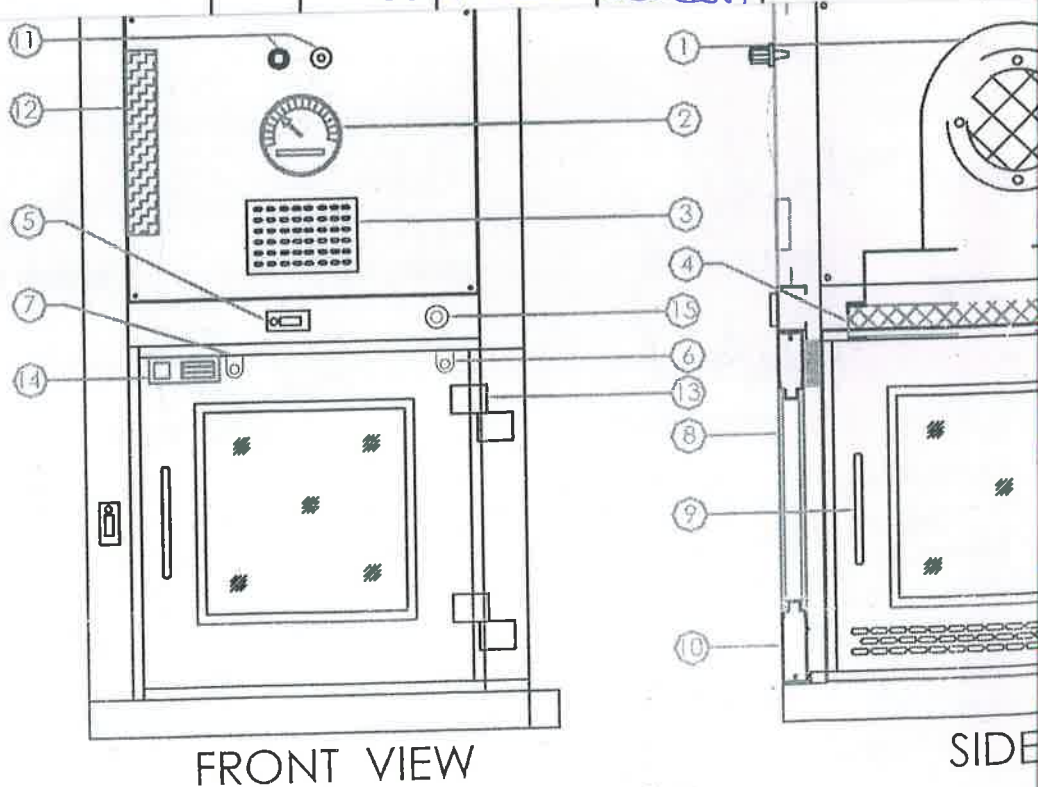

FRONT VIEW

SIDE VIEW

S No	DESCRIPTION
01	DOUBLE INLET BLOWER - 1200CMH
02	MAGNHELIC GAUGE (0-50mm WC).
03	FRESH AIR FILTER (G-4 Filter). Size: 200 x 150 @ 200 FPM
04	HEPA FILTER (H-14,0.3 micron). Size: 650 x 450 x 75mm @ 200 FPM
05	KEY PAD WITH OPERATION INDICATOR.
06	LED LIGHT - 01 NOS.
07	UV LIGHT - 01 NOS.
08	VISION PANEL (TOUGHENED GLASS). Size:300 x 300 mm
09	SS DOOR HANDLE - 2 NOS.
10	SS DOOR - 2 NOS.
11	DOP PORT & UPSTREAM NOZZLE.
12	RETURN FILTER (EU-8 FILTER). Size: 600 x 100 @ 250 FPM
13	SS HINGES - 4 NOS.
14	DOOR INTERLOCK ELECTRO MAGNET - 2NOS.
15	EMERGENCY PUSH BUTTON

SECTION TO VIEW

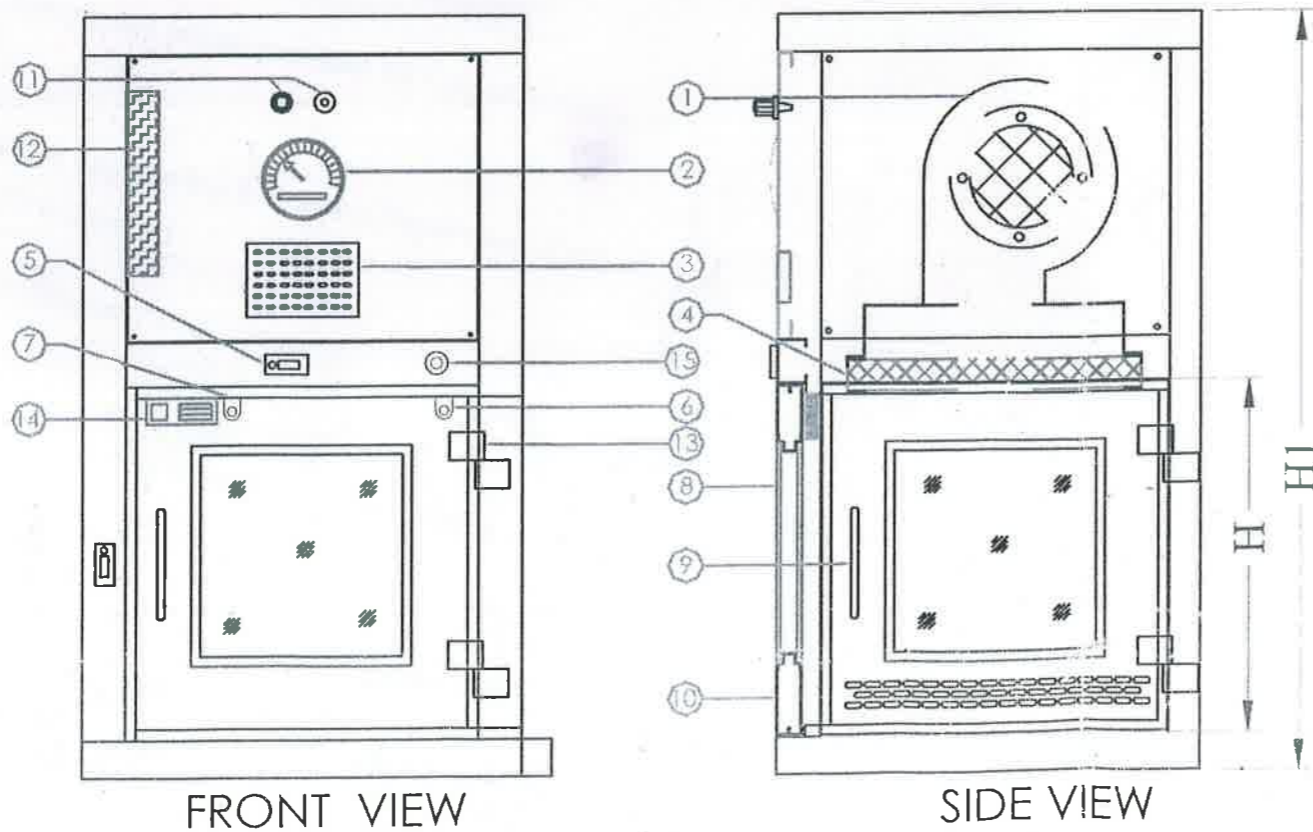
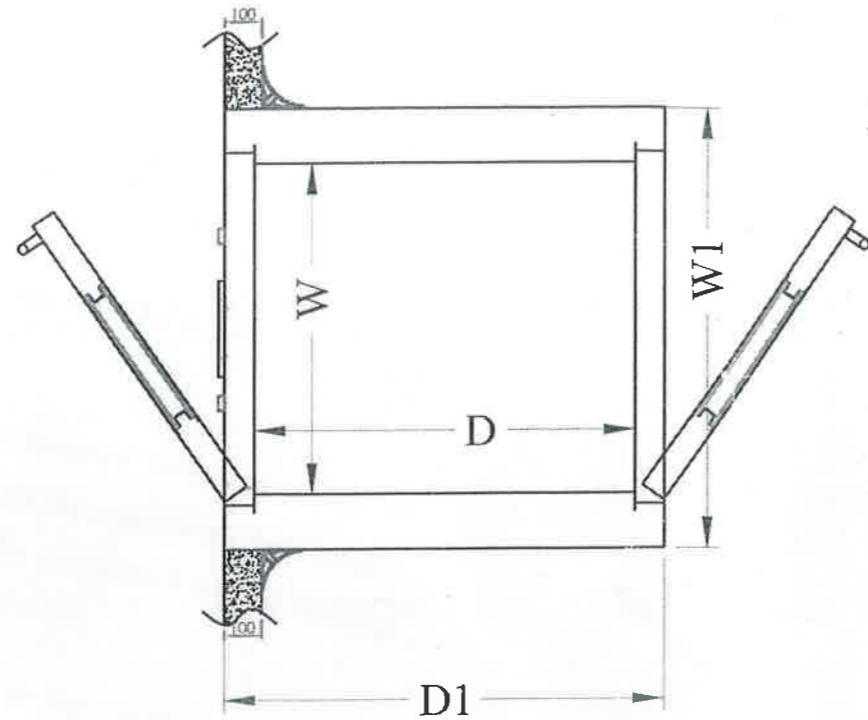

GA Drawing for Dynamic Passbox  
(Seal sanitization room & Dipack Room)

Noted  
12/09/2024  
E(HVNE)

12/09/24  
SM(BBK)

DM(MKM)

DGM(MVS)

SPD  
10/09/2024  
SM(SRS) DGM(KDP)

SL NO	LOCATION	Working area			Overall Size			MOC	QTY
		W	D	H	W1	D1	H1		
01		750MM	600MM	750MM	890MM	680MM	1600MM	SS304	01 NOS

\* INPUT POWER SUPPLY : 230V, 1PHASE, 50Hz.  
\* ALL DIMENSIONS ARE IN MM UNTIL OTHERWISE SPECIFIED.  
\* TOLERANCE WILL BE +/- 5MM